



LEICA **SUMMARIT-S** 35 mm f/2.5 ASPH. / CS

Technical Data.



Illustration 1:2

TECHNICAL DATA

Order no.	11064 (CS: 11050)
Image angle (diagonal, horizontal, vertical)	approx. 74° / 64° / 45°, corresponds to approx. 28 mm focal length in 35 mm format
Optical design	
Number of lenses/groups	11 / 9
Entrance pupil	infinity: 84.77 mm (in front of bayonet in incident light direction), close focus limit: 84.85 mm (in front of bayonet in incident light direction)
Focusing range	0,55 m to ∞
Distance setting	
Scales	Combined meter/feet graduation
Smallest object field	334 mm × 502 mm
Largest reproduction ratio	1 : 11,1
Aperture	
Setting / Function	Electronically controlled diaphragm, set using setting/ selection dial on camera, including half values
Lowest value	22
Bayonet	Leica S bayonet
Filter mount / Lens hood	External bayonet for lens hood (included), internal thread for E72 filter, filter mount does not rotate
Dimensions and weight	
Length to bayonet mount	approx. 122 / 156 mm (without / with lens hood)
Largest diameter	approx. 88 / 132 mm (without / with lens hood)
Weight	approx. 930 / 1080 g (without / with central shutter)



LEICA **SUMMARIT-S** 35 mm f/2.5 ASPH. / CS

ENGINEERING DRAWING



Illustration 1:2

LENS SHAPE

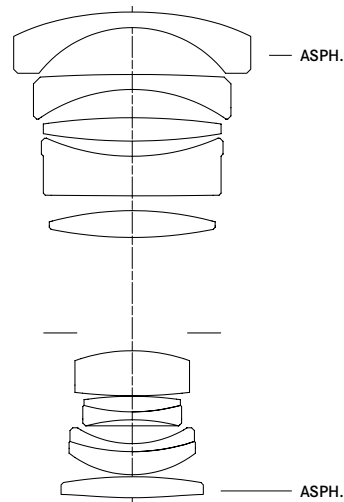

With an angle of view corresponding to that of a 28 mm lens in 35 mm format, the Leica Summarit-S 35 mm f/2.5 ASPH. can be used as a universal wide-angle lens with characteristically dramatic perspectives. At the same time, its unusually fast initial aperture offers fascinating creative potential for the use of selective focusing to isolate subjects from their surroundings. The alternative CS version with a central shutter and a close focusing limit of only 55 cm (~1.8 ft), offers extreme versatility for a wide range of photographic needs.

The combination of a fast initial aperture and a wide angle of view are only possible by the investment of enormous effort in the design and construction of such a lens. And here, Leica employs the benefits of numerous years of experience gained in the production of lenses with aspherical surfaces, a feature very rarely found in such large-diameter lenses. In the front group, a lens with an aspherical surface created in an immensely precise grinding and polishing process guarantees extremely low distortion, and a further aspherical surface is employed in the rear groups. Altogether, five of the eleven lenses arranged in nine groups are manufactured from glass with anomalous partial dispersion, and three are fluoride lenses with particularly low dispersion (colour scattering) characteristics. Rear group focusing in this splash-proof and dust sealed lens ensures consistent imaging performance from infinity to the closest focusing distances and a constant length when focusing.

Thanks to this special construction, the image performance of the Summarit-S 35 mm f/2.5 ASPH., is exceptionally good wide open and can be improved only very slightly in the corners of images by stopping down. A vignetting value of just 1.4 stops, and distortion no greater than 1.7%, even at its closest focusing limit, are imperceptible in practical use. The outcome of the enormous effort invested in the design and construction of this lens is a wide-angle lens that allows photographers to fully exploit its creative opportunities without compromise.



LEICA **SUMMARIT-S** 35 mm f/2.5 ASPH. / CS



Lens with lens hood, illustration 1:2



Lens hood in transport position, illustration 1:2

SCOPE OF DELIVERY

Lens cover S E82 (Order no. 16019), Rear lens cover S (Order no. 16020),
Lens pouch (Order no. 439-606. 099-000), Lens hood (Order no. 12400)



LEICA **SUMMARIT-S** 35 mm f/2.5 ASPH. / CS

MTF DIAGRAMS

Focusing distance

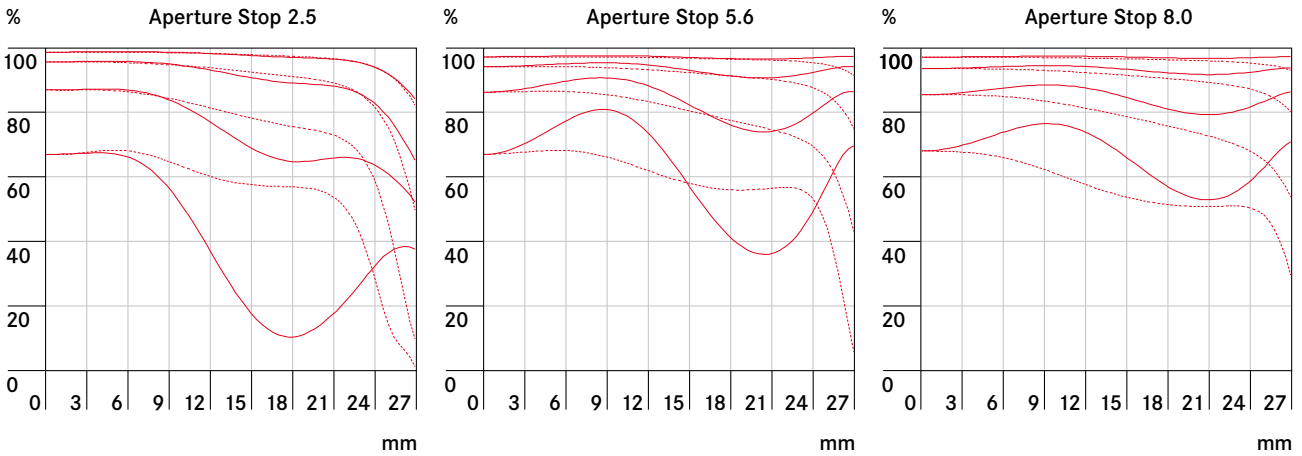

Infinity (∞)

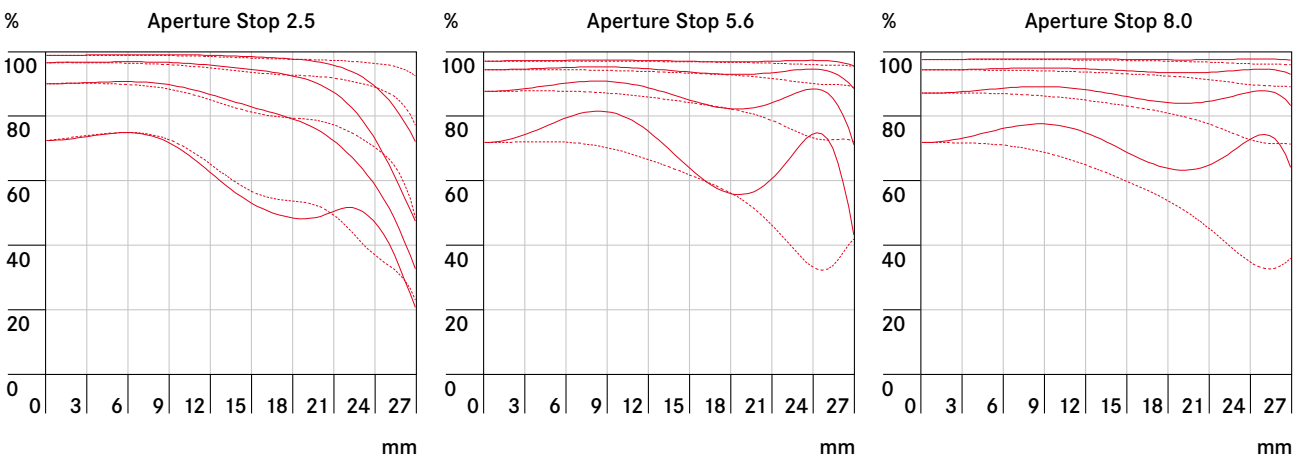

— Sagittal structures
 Tangential structures

MTF GRAPHS

The MTF is indicated both at full aperture and at f/5.6 and f/8 at long taking distances (infinity). Shown is the contrast in percentage for 5, 10, 20 and 40 lp/mm across the height of the 35 mm film format, for tangential (dotted line) and sagittal (solid line) structures, in white light. The 5 and 10 lp/mm will give an indication regarding the contrast ratio for large object structures. The 20 and 40 lp/mm records the resolution of finer and finest object structures.



LEICA **SUMMARIT-S** 35 mm f/2.5 ASPH. / CS

VIGNETTING-/DISTORTION DIAGRAM

Focusing distance

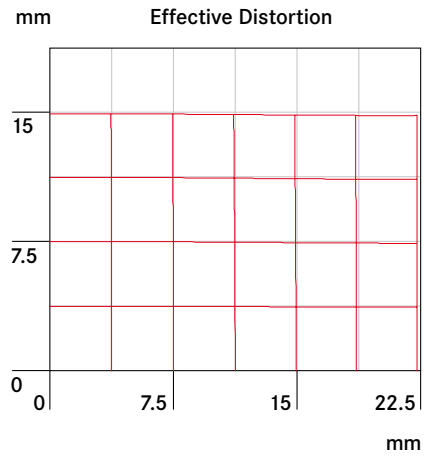
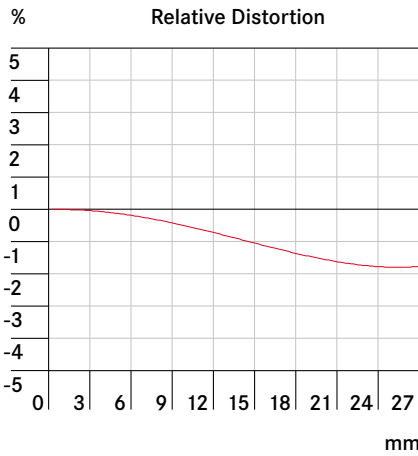
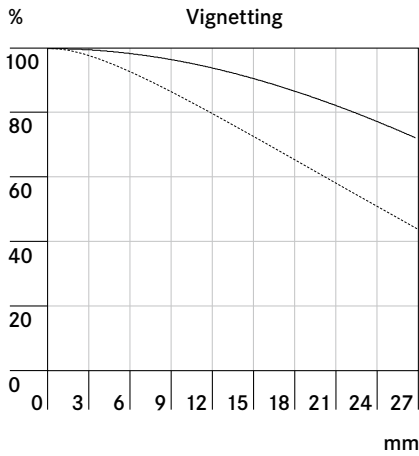

Infinity (∞)

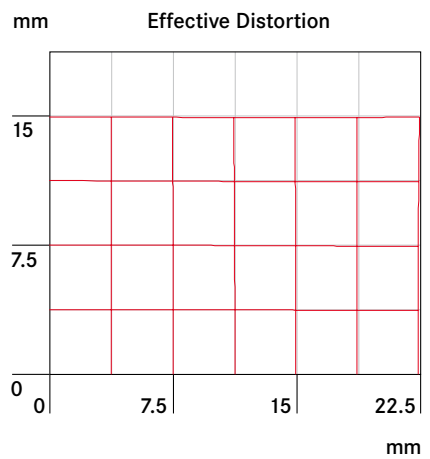
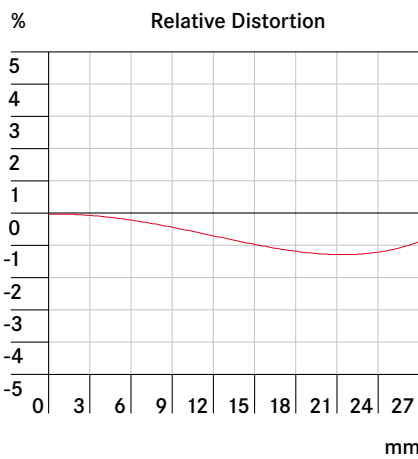
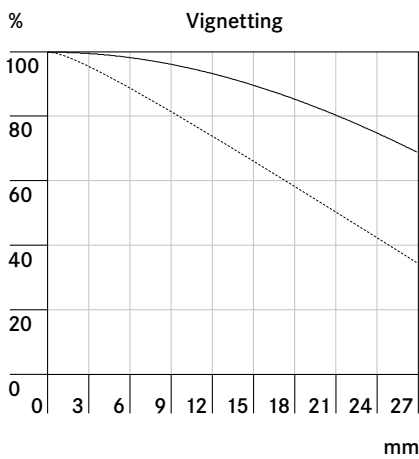

..... 2.8
 ——— 8.0, 5.6

DISTORTION & VIGNETTING

Distortion is the deviation of the real image height (in the picture) from the ideal image height. The relative distortion is the percentage deviation. The ideal image height results from the object height and the magnification. The image height of 27.04 mm is the radial distance between the edge and the middle of the image field for the format 30 mm x 45 mm. The graph of the effective distortion illustrates the appearance of straight horizontal and vertical lines in the picture.

Vignetting is a continuous decrease of the illumination to the edges of the image field. The graph shows the percentage loss of illumination over the image height. 100% means no vignetting.



LEICA **SUMMARIT-S** 35 mm f/2.5 ASPH. / CS

DEPTH OF FIELD TABLE

 ∞ feet ∞ m	Aperture Stop							Magnification
	2,5	4	5,6	8	11	16	22	
0,55	0,539 - 0,562	0,533 - 0,568	0,527 - 0,576	0,518 - 0,588	0,507 - 0,604	0,490 - 0,634	0,472 - 0,675	1/11,1
0,7	0,679 - 0,722	0,669 - 0,734	0,658 - 0,749	0,642 - 0,773	0,623 - 0,806	0,595 - 0,869	0,565 - 0,962	1/15,3
0,8	0,772 - 0,831	0,758 - 0,848	0,742 - 0,870	0,721 - 0,904	0,696 - 0,952	0,658 - 1,047	0,620 - 1,195	1/18,1
1	0,953 - 1,053	0,930 - 1,084	0,905 - 1,122	0,870 - 1,185	0,831 - 1,277	0,775 - 1,472	0,718 - 1,817	1/23,7
1,5	1,39 - 1,64	1,33 - 1,72	1,28 - 1,83	1,20 - 2,03	1,12 - 2,35	1,01 - 3,22	0,91 - 6,01	1/37,6
2	1,79 - 2,27	1,70 - 2,44	1,61 - 2,68	1,49 - 3,15	1,36 - 4,06	1,19 - 8,01	1,05 - ∞	1/51,6
3	2,54 - 3,68	2,35 - 4,19	2,17 - 4,99	1,94 - 7,06	1,72 - 14,9	1,455 - ∞	1,23 - ∞	1/79,4
5	3,81 - 7,33	3,38 - 9,82	3,00 - 16,19	2,57 - 1209	2,19 - ∞	1,76 - ∞	1,44 - ∞	1/135
∞	15,2 - ∞	9,91 - ∞	7,12 - ∞	5,02 - ∞	3,69 - ∞	2,58 - ∞	1,91 - ∞	1/ ∞



Set distance [m]